

Data Sheet for T-D5000HT

Specifications	
Type :	Rechargeable Nickel Cadmium High Temperature Cell
Model (P/N) :	T-D5000HT
Nominal Dimension : (with sleeve)	$\Phi = 33.0^{+0}_{-1.0} \text{ mm}$ $H = 58.0 \pm 0.5 \text{ mm}$
Applications :	Recommended discharge current 500 to 5000 mA
Nominal Voltage :	1.2V
Nominal Capacity :	5000 mAh when discharge at 100 mA to 1.0 V at 20°C
Standard Charge :	250 mA for 48 hrs at 20°C
Fast Charge :	500 mA (0.1C) with charge termination control Recommended control parameters Timer: 140 % nominal input
Service Life :	> 500 cycles
Continuous Overcharge :	250 mA maximum permissible current No conspicuous deformation and / or leakage
Weight :	145 g
Internal Resistance :	Max 20 m Ω at 1000 Hz measured within 1 hour after standard charge
Max. Charging Voltage :	1.5 V at 250 mA charging
Ambient Temperature : Range	Standard Charge : 0°C to 45°C Fast Charge : 10°C to 45°C Discharge : -20°C to 65°C Storage : -20°C to 45°C

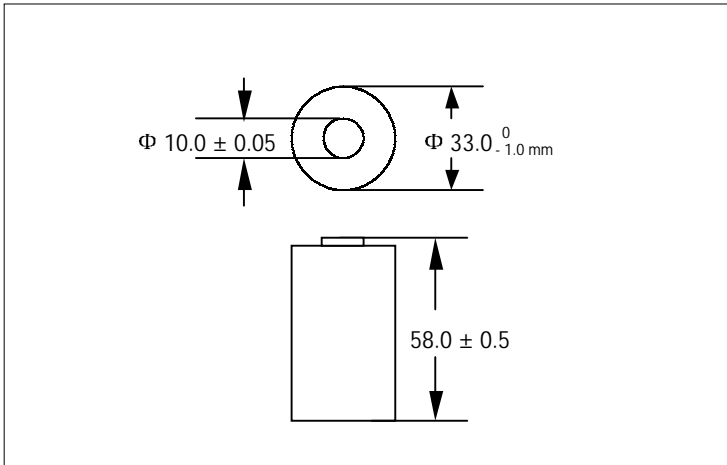

Characteristics

Charge Curves (20 °C)

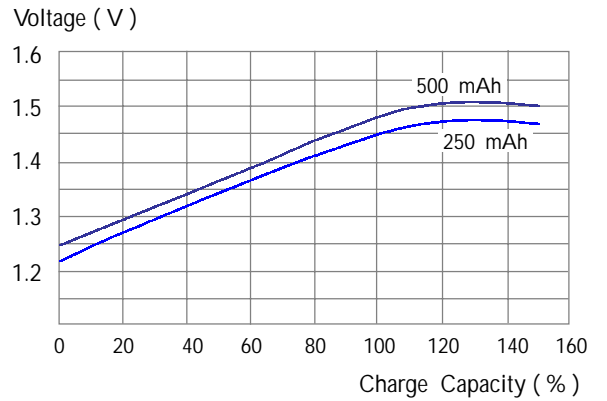

Discharge Curves (1000 mA)

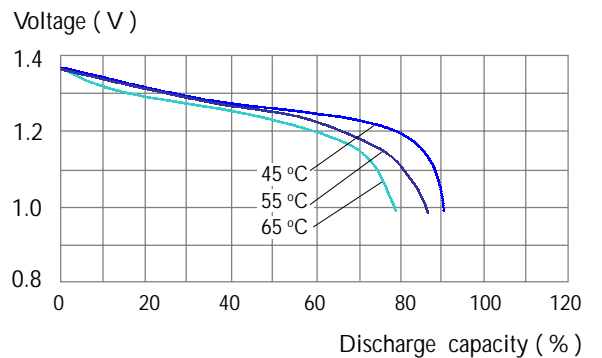

Charge/Discharge Efficiency vs. Temperature

