

Data Sheet for T-AA700

Specifications

Type :	Rechargeable Nickel Cadmium Standard Cell
Model (P/N) :	T-AA700
Nominal Dimension : (with sleeve)	$\phi = 14.5^{0}_{-0.5}$ mm H = 49.0 ± 0.5 mm
Applications :	Recommended discharge current 70 to 700 mA
Nominal Voltage :	1.2V
Nominal Capacity :	700 mAh when discharge at 140 mA to 1.0 V at 20°C
Standard Charge :	70 mA for 15 hrs at 20°C
Fast Charge :	280 mA (0.4C) with charge termination control Recommended control parameters Timer: 140 % nominal input
Service Life :	> 500 cycles
Continuous Overcharge :	70 mA maximum permissible current No conspicuous deformation and / or leakage
Weight :	23 g
Internal Resistance :	Max 25 m Ω at 1000 Hz measured within 1 hour after standard charge
Max. Charging Voltage :	1.5 V at 70 mA charging
Ambient Temperature : Range	Standard Charge : 0°C to 45°C Fast Charge : 10°C to 45°C Discharge : -20°C to 45°C Storage : -20°C to 45°C

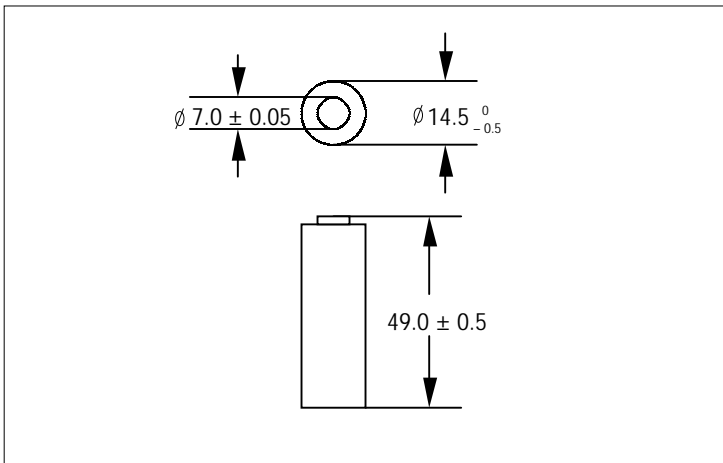

Characteristics

Charge Curves (20 °C)

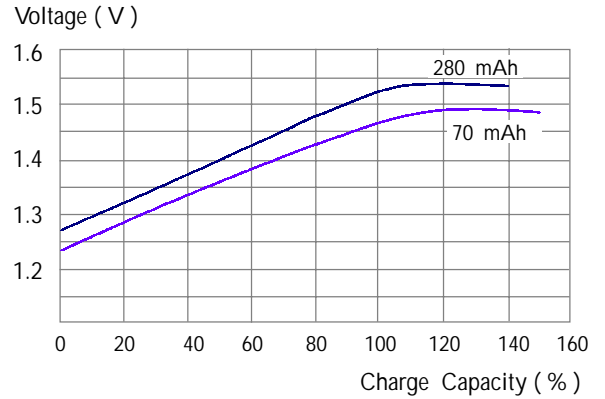

Discharge Curves (20 °C)

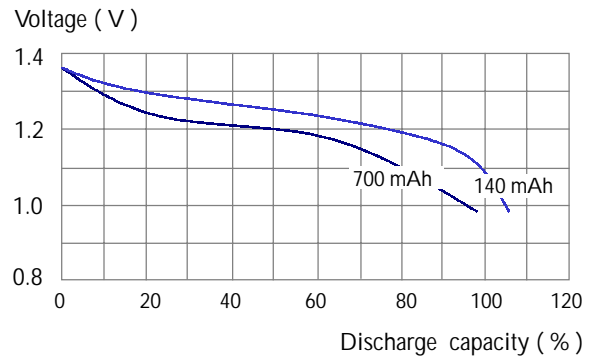

Charge/Discharge Efficiency vs. Temperature

